

# FICHE TECHNIQUE

## CROCHET DE GOUTTIERE HRRL-VP

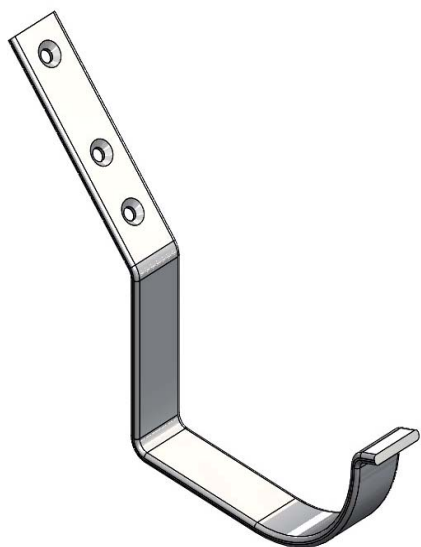

no.Art	matériel	largeur	épaisseur	poids	emballage
HRRL-GVP	galva	30 mm	5 mm	455 g	25 p/bte
HRRL-INVP	inox	30 mm	5 mm	485 g	25 p/bte
HRRL-KVP	cuivre	30 mm	5 mm	510 g	25 p/bte

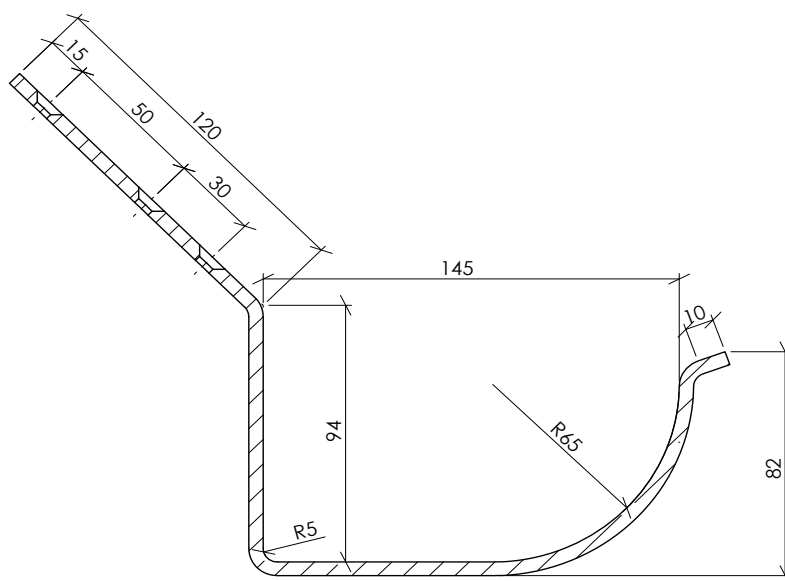

Synonyme de QUALITÉ et SERVICE

APOK KAMPENHOUT  
siège principal  
Oudestraat 11, B-1910 Kampenhout  
Tél.: +32 (0)16 61 72 62 - Fax: +32(0)16 61 72 81  
Site: [www.apok.be](http://www.apok.be) - Email: [info@apok.be](mailto:info@apok.be)

